

## Fitting 50Amp Denso/WOSP Alternator to Caterham 2.0L XE engine

With thanks to Roger Swift

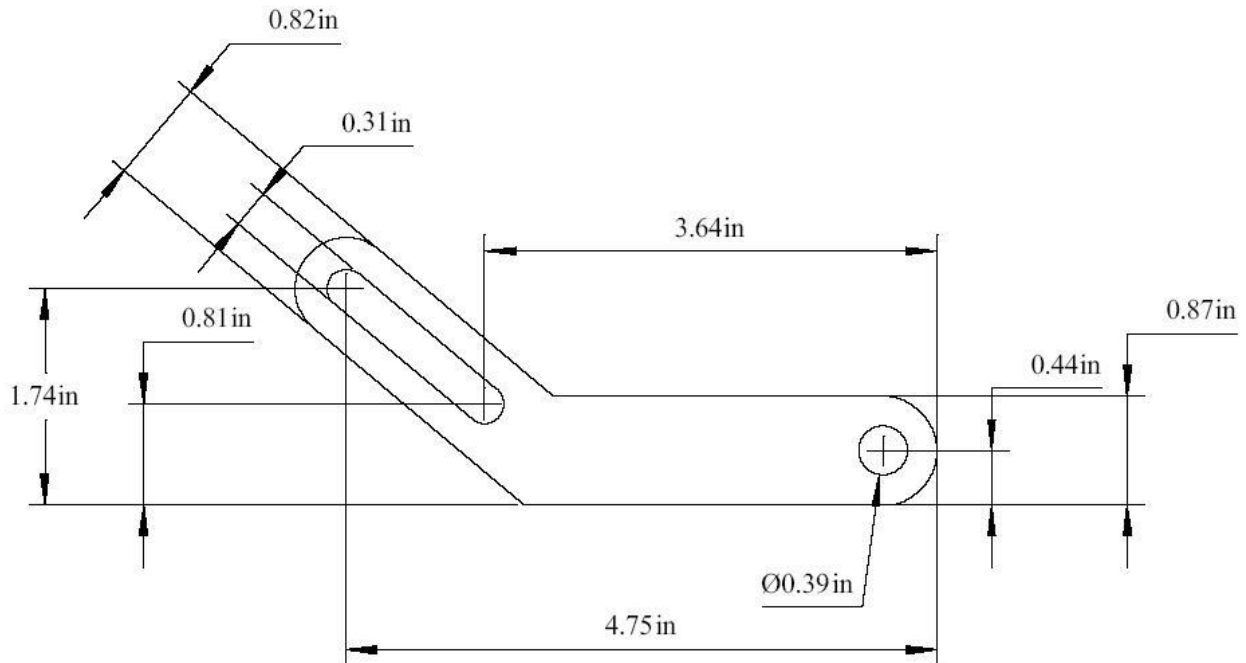

Drawn: R.J.Swift

Title: Strap for Denso 50A Alternator on Caterham 2.0XE

Date: 6/09/04

Material: 6mm Mild Steel

Bush out the alternator bottom mounting

Bush size: 409" OD x .925" long x M8 clear to suit Caterham M8 bolt

Remove .105" from the front of the Caterham engine mount alternator mounting tube to give a finished length of 3.047" (assumes all mounts are identical!) This should put the front face of the SBD crankshaft pulley.022" below the face of the alternator pulley (Alternator pulley front face is not necessarily the same depth as the crankshaft pulley front face)

Shim out strap mounting bolt spacer if necessary.

Belt is 4 vee x 675mm long (Brown Brothers UGCGMV40675)

***Free technical support is available on our website. If you require personalised technical support training, this is available at a chargeable rate.***