

June 2021

## SBD Hayabusa Dry Sump System Installation Sheet (OS-DSK-BUSA-01)

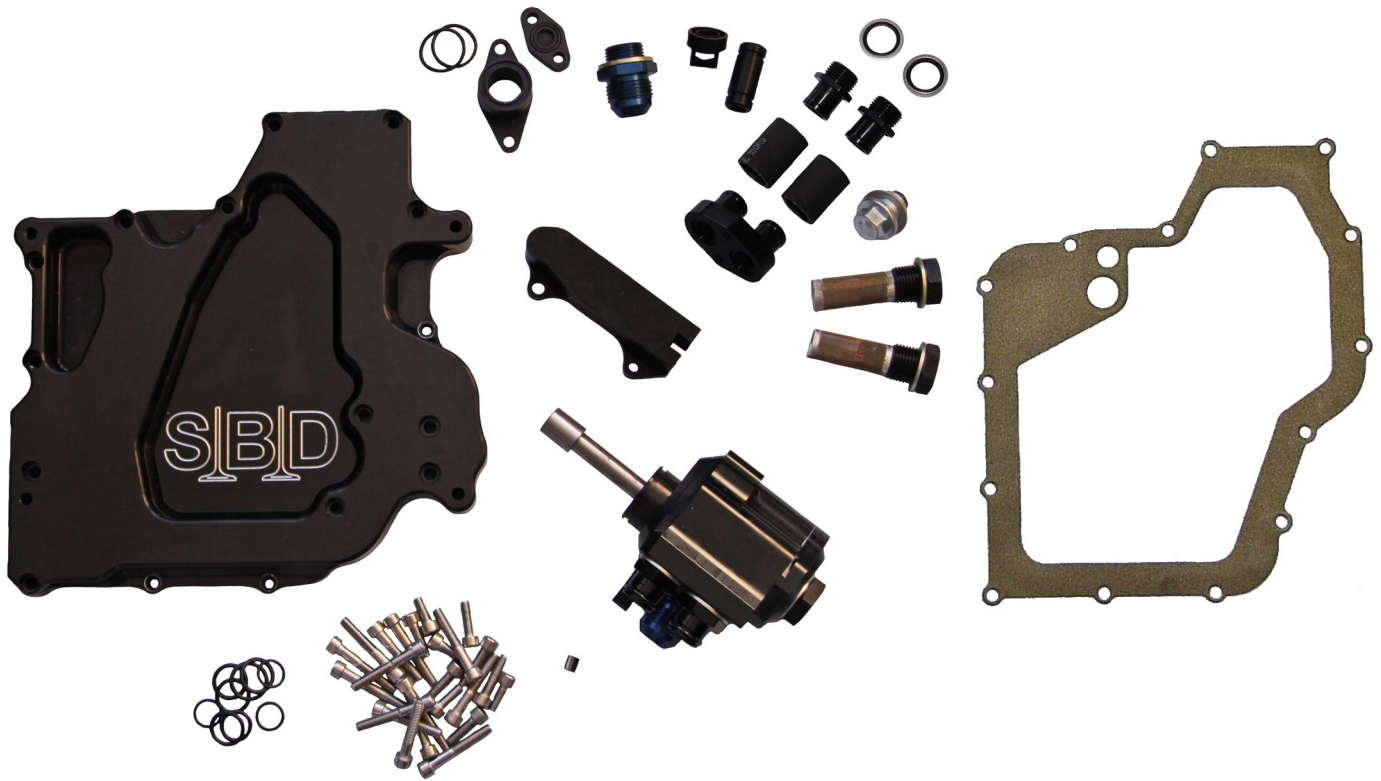

**Please note:**

**All couplings/fittings are loose & require tightening before use; also ensure that all components are clean before use.**

**We suggest the use of an oil tank with the ability to hold at least 5litres of oil.**

The depth of the dry sump pan is 31mm.

### Busa Dry Sump Bolts

#### **Included in Kit:**

##### **Sump**

M6 x 40 x 11off  
M6 x 25 x 3off

##### **Sump Scavenge Flange**

M6 x 35 x 2off

##### **Oil Pick Up Flange**

M6 x 16 x 2off

##### **Oil Cooler Blank (fitted to Block)**

M6 x 16 x 2off

##### **Pump**

M6 x 20 x 1off  
M6 x 35 x 1off

##### **Oil Relief Valve**

M6 x 20button heads x 2off

Please note some of the pictures in the instruction sheet show components in gold, this is purely to make it easier to see the seals and fittings. All our kits are anodised black.



**1**  
Insert the filters, coupling and blank as shown left & below.



**2**  
To make later installation of the scavenge pump easier, trial fit the pump by aligning the drive on the shaft with the pressure pump, remove the scavenge pump and keep it to one side for now.

Pressure Pump

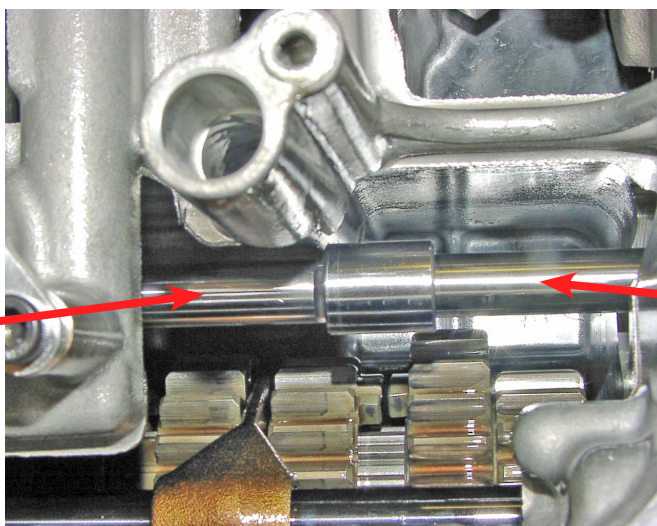

Scavenge Pump



### 3

Fit a new Genuine Suzuki pick-up pipe O-ring (available from your Suzuki dealer), use a suitable grease to hold it in place during assembly.

The breather tube must be removed.

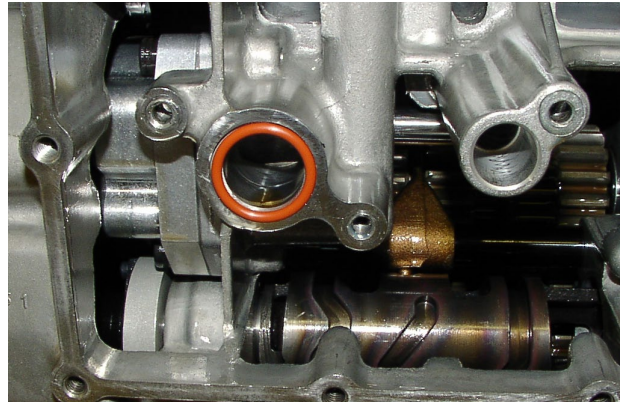

### 4

Fit the new pick up pipe, use Loctite 243 on the bolts and tighten to the specified torque of 10NM. We recommend the bolts are wire-locked

Be sure to fit the outer O-ring.

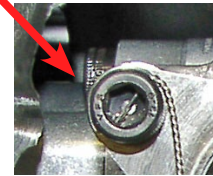
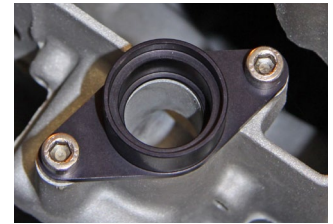

### 5

The pick up pipe you have is the newer design which means once you have fitted it onto the engine, you shim the height with the 'o' ring supplied to ensure it applies pressure to the sump pan.

Some Suzuki crank cases have been machined at different heights where the sump is fitted, so we have designed an oil pick up pipe/sump connecting pipe that can accommodate these variations. Most blocks are the same and if you use 3 o-rings as shown in the picture, this will accommodate the standard installation.

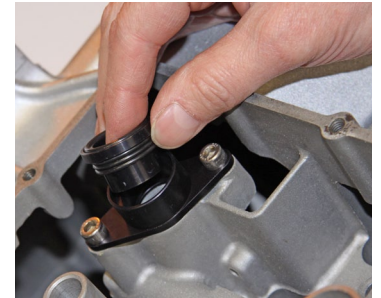
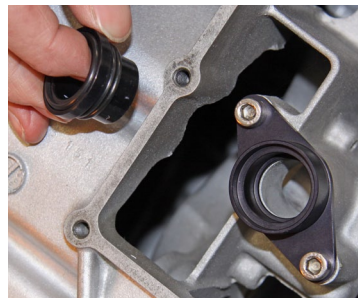

Using a straight edge across the underside of the pick up pipe as shown, you need to measure a gap on both sides of approximately 0.5mm. Due to the springy design of the o-rings, this will allow some accommodation if this dimension is greater than specified, but if the dimension is less than 0.5mm when gentle pressure is applied, to the oil pick up pipe, then add additional o-ring (shown below) supplied and recheck.

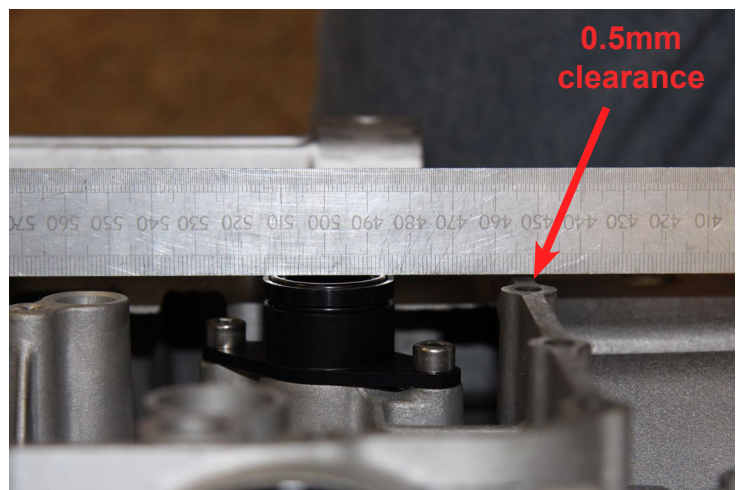

# 6

Before fitting the new sump, ensure that the standard pressure relief valve is working correctly.

Remove the standard pressure relief valve from the engine & replace the original o-ring with the new thinner o-ring supplied.

This allows correct fitment into the new relief valve housing (original o-ring is too large and will jam).



# 7

Put some lubrication (engine oil) on the seal & insert the pressure relief valve into the new relief valve holder fully. It should slide in with a slight resistance.



# 8

Put the pressure relief valve retainer in the end of the holder, ensuring both seals are fitted.



# 9

Insert the location dowel in the dry sump pan

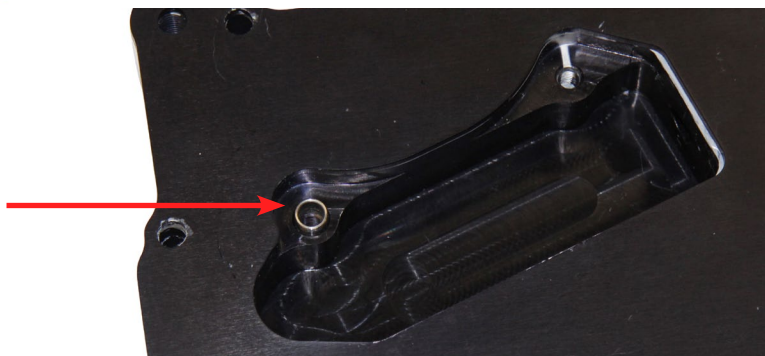

# 10

Place the relief valve holder in position, sliding the o-ring end in place first, then with gentle pressure on the opposite end of the holder, it should easily locate over the dowel.





# 11

Apply a small amount of Loctite 243 retainer to bolts. Tighten the M6 x 16 bolt.



Additional screw hole is only to aid installation & removal of the oil pressure relief valve holder.



# 12

Apply some engine oil to the o-rings. Insert the oil pressure relief valve connecting tube into the sump pan (as shown). This will locate into the hole where the standard relief valve was originally fitted, when the new sump is installed.



# 13

Our special sump gasket is included in the kit.

Place the gasket in position, this will cover the bolts & although it is not necessary, you may like to make additional holes in the gasket to allow the bolt heads to protrude through the gasket. See picture below.

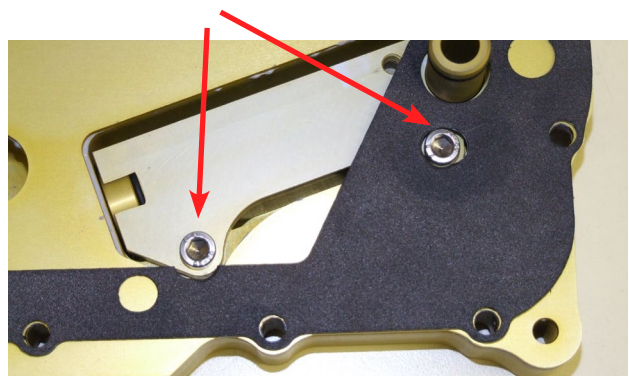

# 14

When fitting the sump ensure that the new relief valve connecting tube slides into position with a slight resistance, using the supplied bolts.

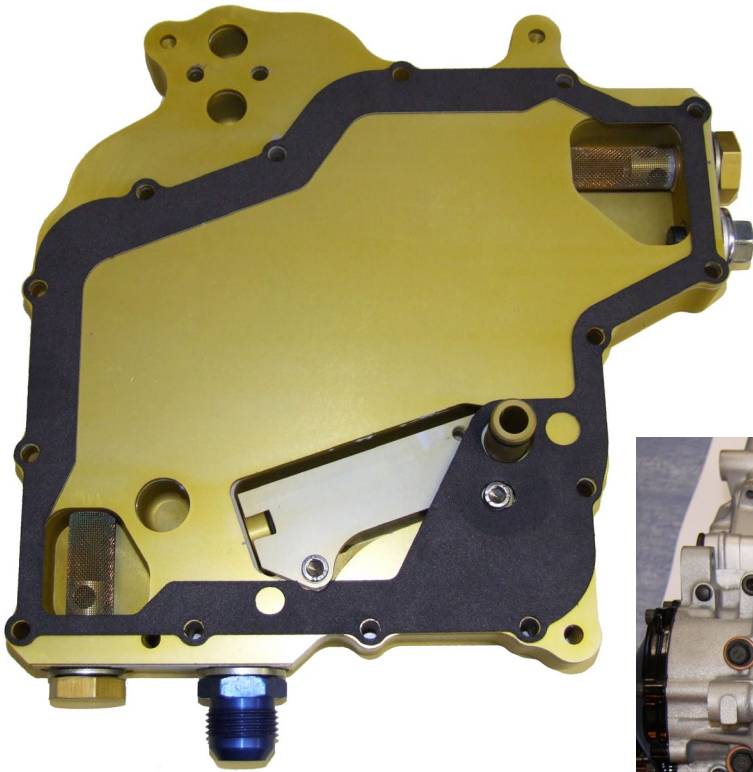

# 15

Remove the standard oil feed blank from behind the oil filter, this is now left open to allow oil through the filter, if this is **not** done **ENGINE FAILURE WILL OCCUR!** We recommend fitting a new oil filter

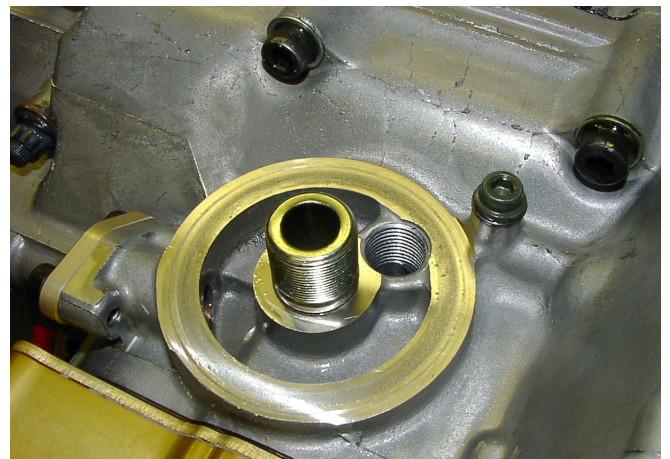



## Optional change of outlet pipe

You have 2 options for the outlet pipe from the scavenge pump, either from the side or if you wish to use the underside fitting, by swapping the 2 fittings around as shown. You will need to use a button head bolt as shown below to ensure clearance for your coupling. The bolt should be inserted before changing the coupling around.

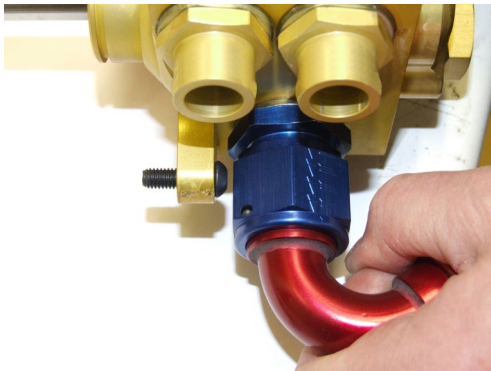
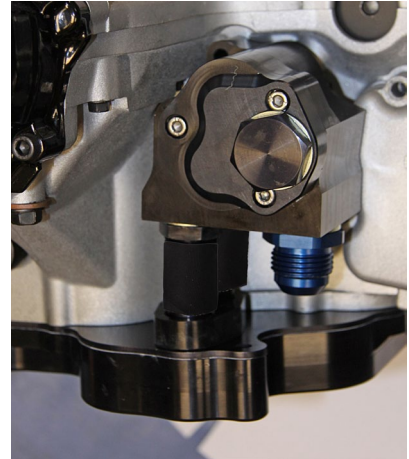
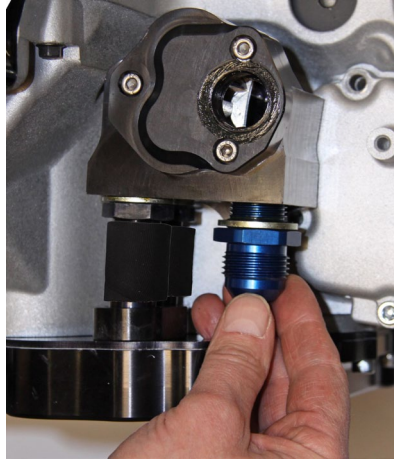

## Electric Water Pump

The scavenge pump replaces the original water pump and you have a few options when converting to electric water pump. We have shown a picture of a small pump, which we use on all our own installations all the way up to 400bhp turbo engines.

Please see our website for further details and information.



# 16

Ensure that the O-ring is fitted to the end of the scavenge pump using the original water pump O-ring. Apply a suitable lubricant to the O-ring to help installation.

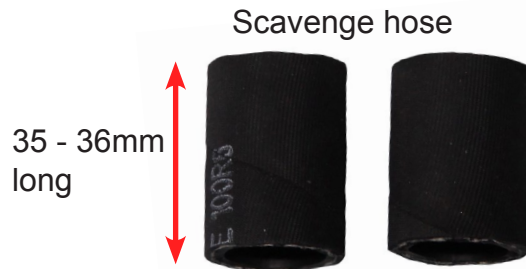
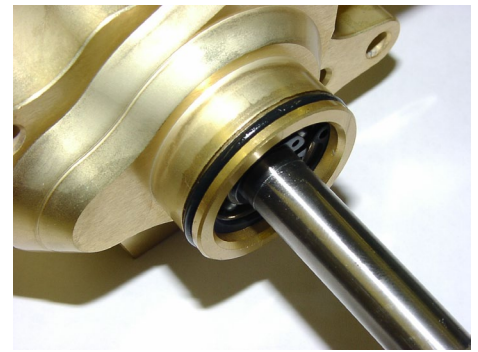
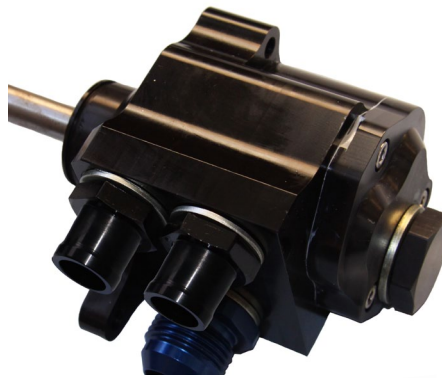

# 17

Because the scavenge pump (picture 17a) sits at a slight angle, to allow correct alignment the scavenge flange tube assembly is correspondingly machined to ensure correct alignment. To ensure you fit the assembly correctly, the tubes should tilt backwards as shown in 17b (17b also has scavenge joining hoses fitted). Once you have confirmed the correct direction, use a small amount of lubricant on to the inside of the hoses and press assembly together as shown in 17a.

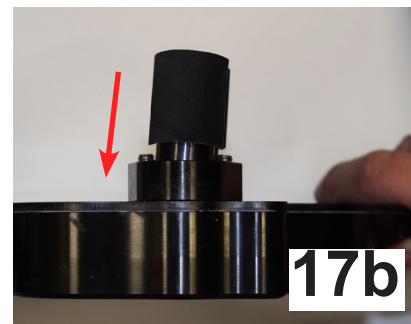
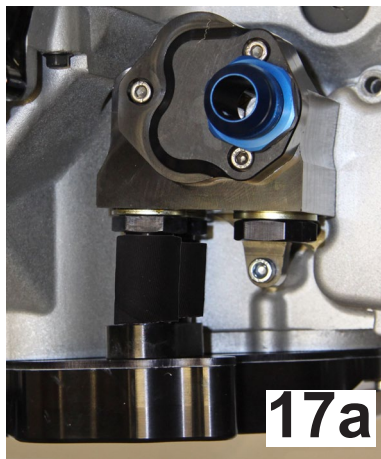

# 18

Carefully slide into place and engage the pre-aligned shaft with the pressure pump shaft, do not force.

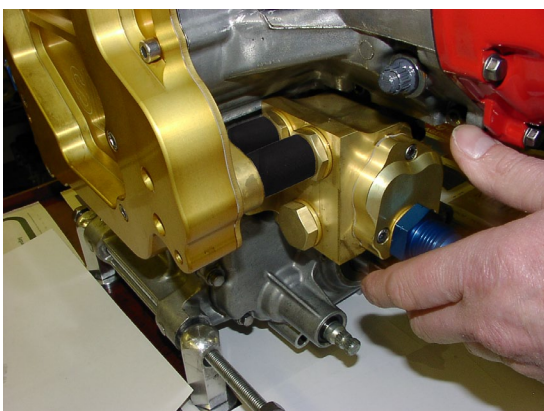
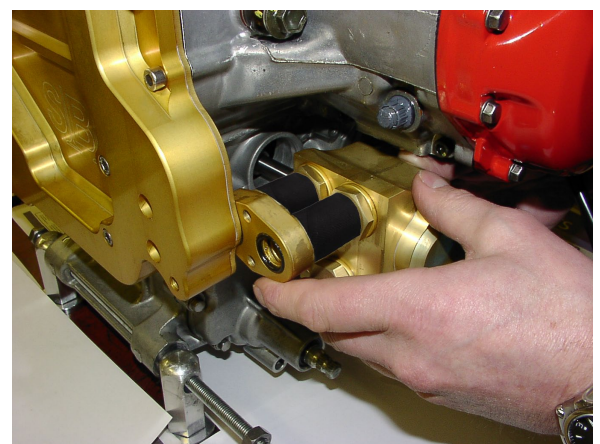

# 19

Secure the pump using the relevant bolts.



## 20

Apply Loctite 243 to the flange retaining bolts and tighten

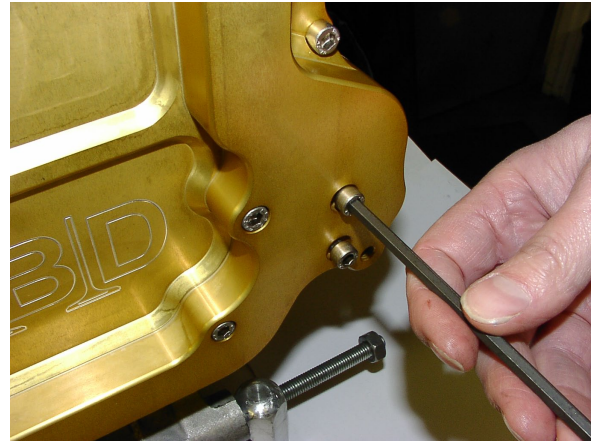

## 21

Ensure that all components are located correctly.

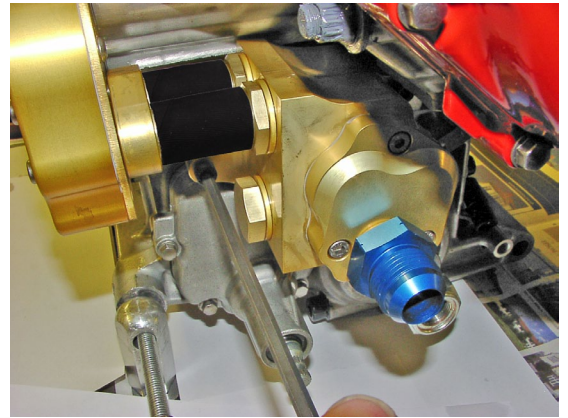

## 22

Fit the new oil cooler take off blanking plate with the supplied O-ring.

If any oil cooler is to be used, it **MUST** be fitted on the return line (scavenge) of the oil system only!



Alternatively, the outlet fitting can be moved to the bottom of the pump, the fitting may need to be machined in order to reduce the height of the fitting, this should provide sufficient clearance for the oil hose to run under the engine.

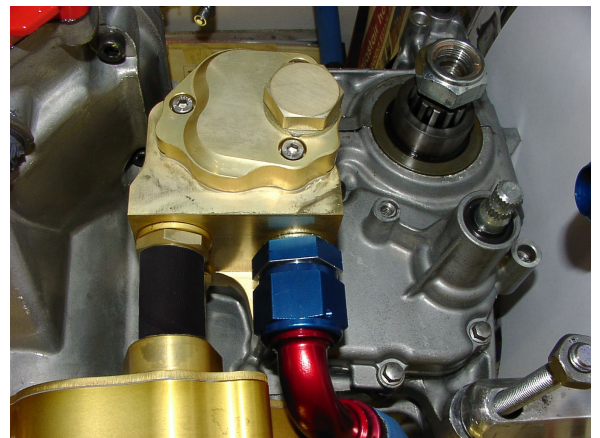

## **IMPORTANT NOTE**

With our latest design the scavenge pump has been significantly improved to increase the rate of oil evacuation from the engine. The engine must remain open to atmosphere, so that the pressure within the engine can equalise. The original breather plate could be retained (the 2008 engine has a reed valve fitted into this breather & it must be discarded).

The breather must be connected to a catch tank which vents to atmosphere, do not connect directly to the main oil tank.

On a competition car or bike we recommend a large catch tank with both breather hoses (one from tank and one from engine) going into the catch tank, the fittings must be of suitable size so that there is no restriction imposed.

It is vital that the hoses are connected to the catch tank in such a way that they cannot be blocked as this would effectively block the breathing of the engine, we often see hoses in catch tanks submerged in old oil or pushed too far into the catch tank with the end of the hose flat against the bottom of the tank, this is NOT acceptable.

Catch tanks should be regularly checked, emptied and cleaned.

## **23**

We can supply a slim-line breather plate to be fitted in replacement of the bulky standard item.

**(OS-DS-BUSA-BREATHER-01)**

Remove the standard breather housing and fit the new breather plate.

Bolts supplied: M6 x 25 x 4off

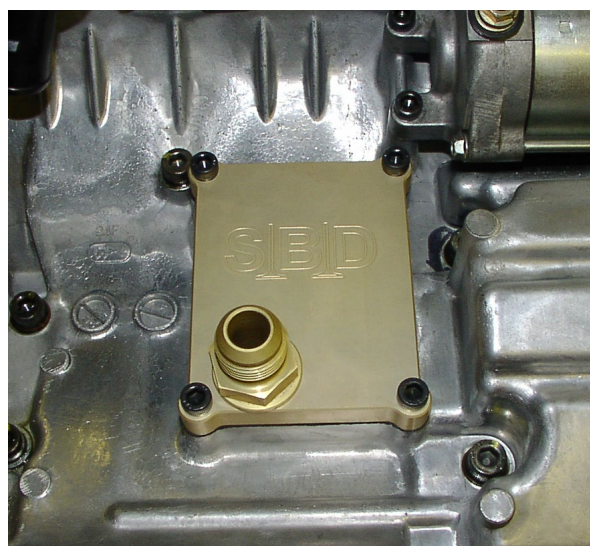

### **Positioning of the dry sump tank**

The bottom of the dry sump tank ideally should be level with the bottom of the engine. Then the outlet pipe from the bottom of the tank goes directly to the inlet on the sump pan. This should be as short as possible, having the bottom of the tank level with the bottom of the engine means that if the engine is left for periods of time, that the oil levels will go down and bleed oil back into the engine. This way the oil levels will equalise and you will still have sufficient oil left in the tank if the engine has been left for a long period of time. The return line comes from the scavenge pump which you have now mounted to the side of the engine. This returns to the top of the tank and if the engine is to be used for sustained competition use, we recommend the use of an oil cooler.

The Suzuki hayabusa engine transfers a lot of its heat into the oil, in fact almost as much as goes into the water system. So ideally this oil cooler should be of a reasonable size and not less than 16 row x 230mm wide. The oil cooler should be of the same –12 fitting size as the rest of the hayabusa dry sump system. The oil cooler should be mounted in the return line from the scavenge pump to the top of the oil tank.



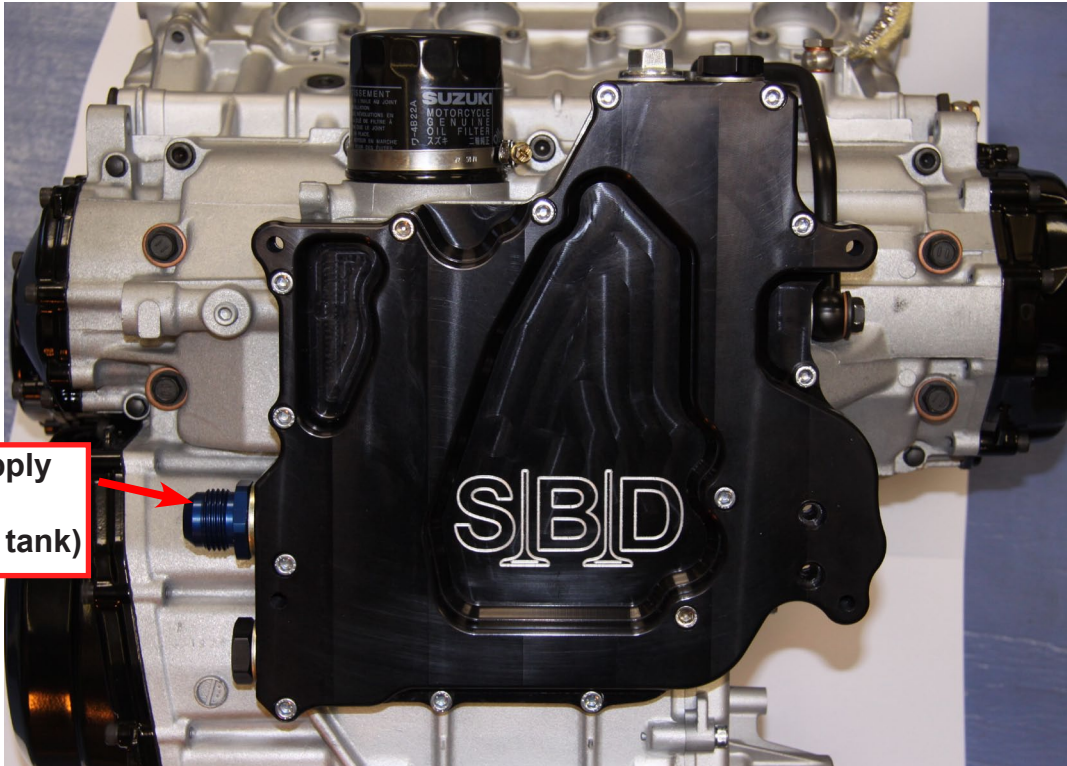

**-12JICSupply  
(Oil from  
bottom of tank)**

**If required - Oil Cooler to be fitted on return line (scavenge) to tank**

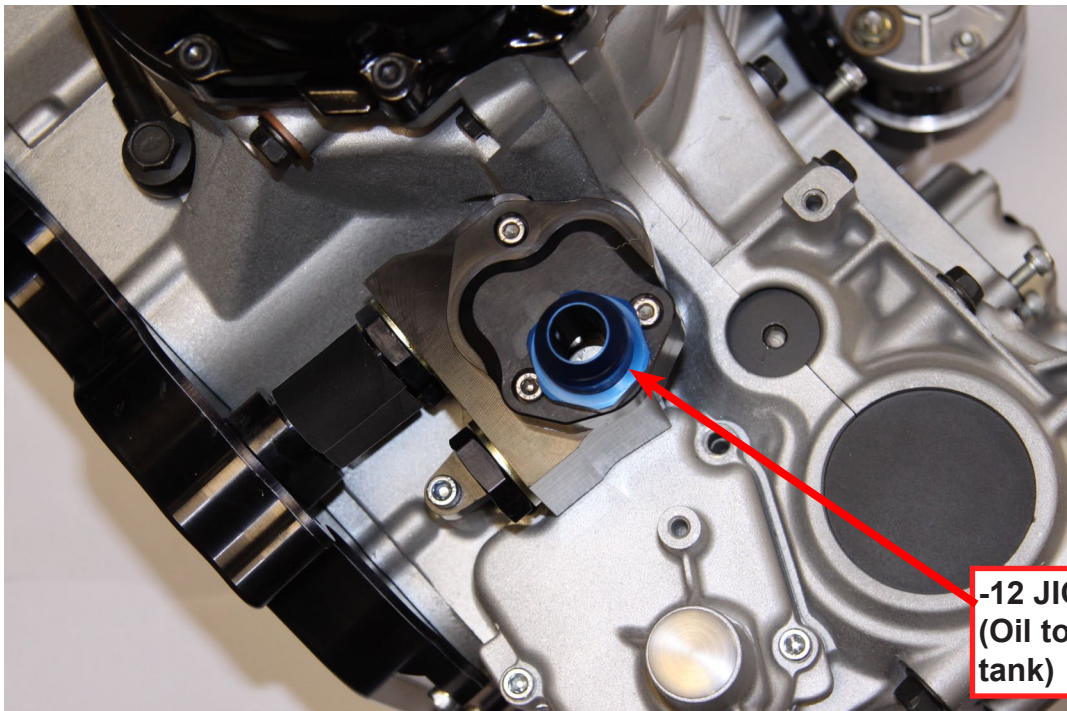

**-12 JIC Return  
(Oil to top of  
tank)**

Please see separate information sheet 'Dry Sump System Level Information re SBD Dry Sump Tanks' for details about filling your system with oil and the recommended oil levels.

SBD Hayabusa Dry sump pan  
OS-DSK-BUSA-01, M8 mounting dimensions

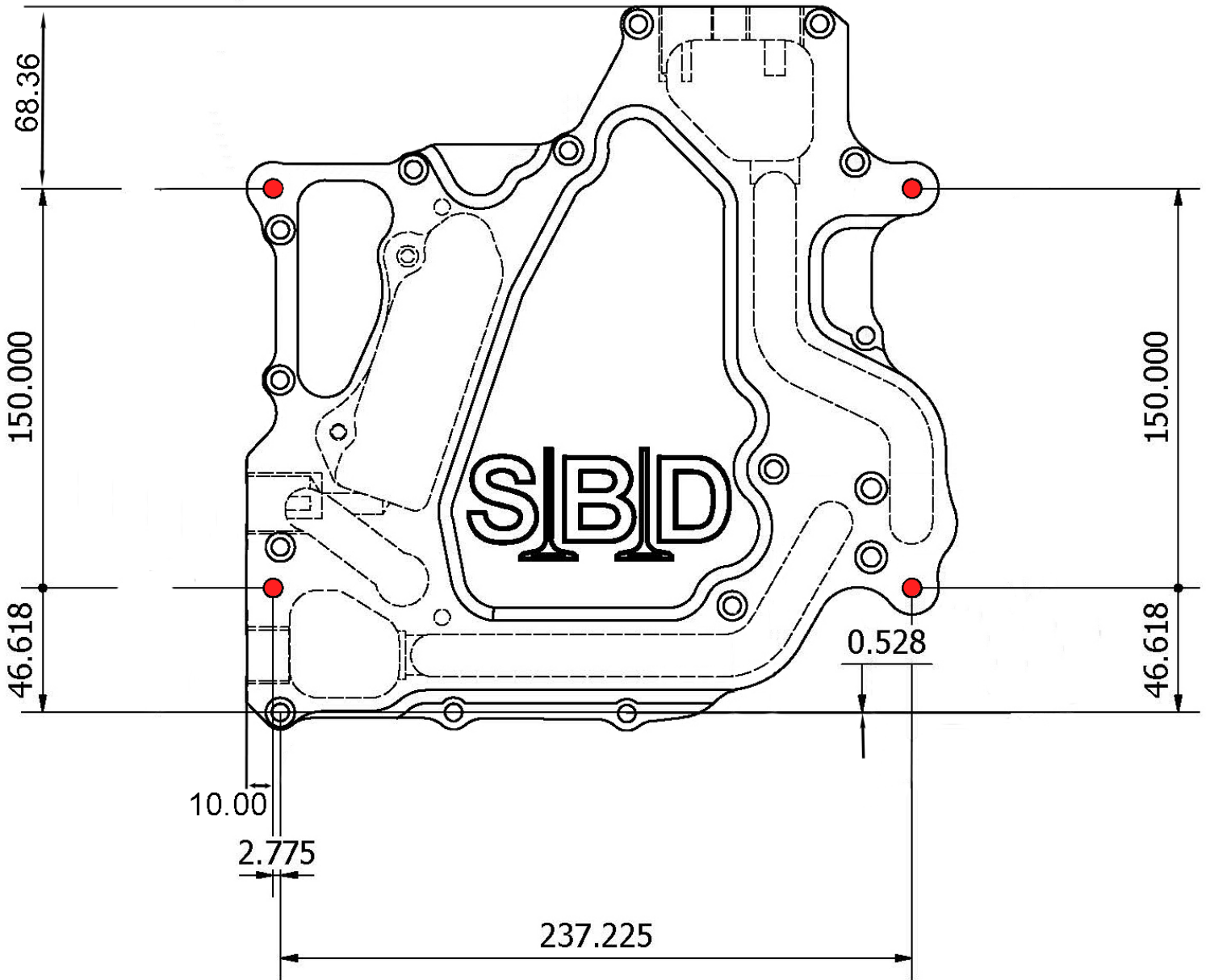

● M8 Mounting Holes





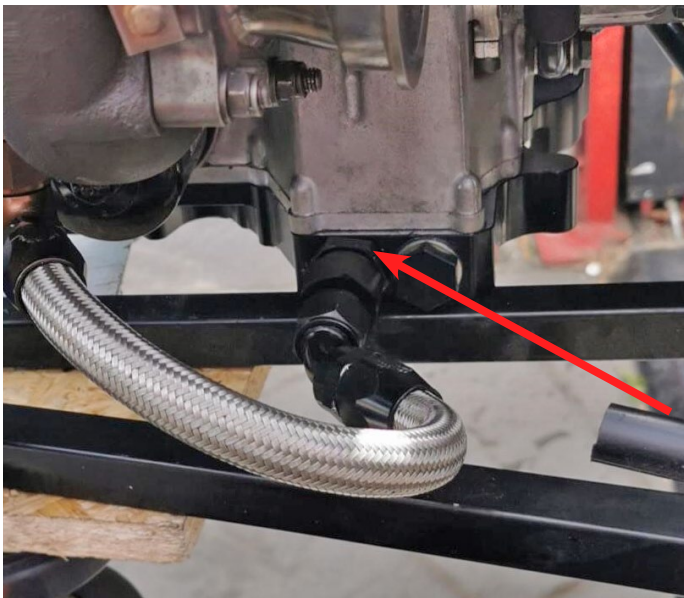

## Turbo engine applications

When using a turbo with the SBD dry sump system, you remove the sump plug with the magnetic fitting and replace it with the -12 turbo drain fitting. This is right next to the scavenge fitting in the dry sump pan, which helps to give increased suction in this area to help with turbo drainage (pictured right on a customer's engine).

Turbo drain fitting part number is **OS-A-12XM20X1.5**



The recommended size is -12 and used by all our turbo specialists.

## Recommended Options

We recommend the use of the high speed oil pump gear **OS-OP-BUSA-OPG**, this changes the gearing of the standard oil pump and increases it's speed by approximately 10%, this improves tick-over oil pressure by a few psi which is always a benefit.

This is only a recommended option and not essential. The clutch will need to be removed in order to fit this component and can be fitted at a later date if required.

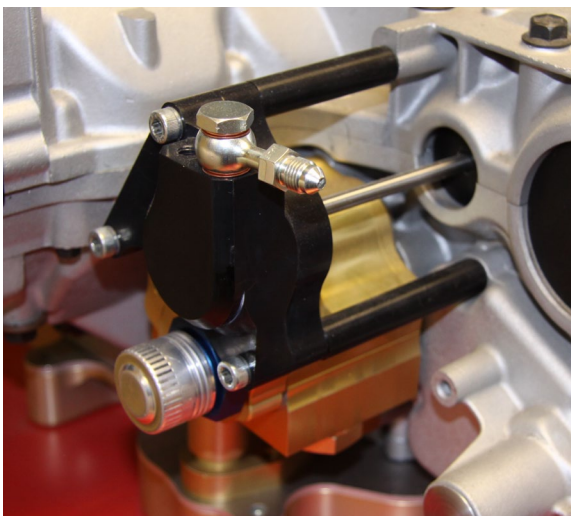
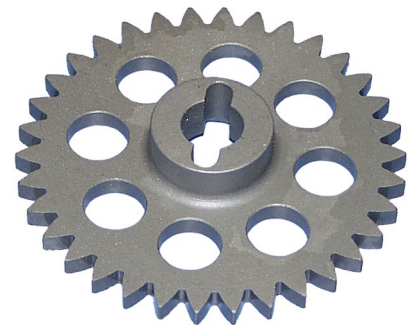

Although the original slave cylinder kit can be used with the dry sump system, some modifications would be required depending upon your installation.

We produce a small compact slave cylinder kit which fits neatly with our dry sump system for either chain drive or by altering the fitting kit accommodate a range of output flanges, which may vary according to your installation.



## Key Factors in our Design

### Remote PRV (pressure relief valve) housing for pressure stabilisation

When we first started using the Hayabusa engine in wet sump form, we logged everything on the engine as we do with all engines we develop. We soon discovered that oil pressure would become an issue on high speed corners, this is mostly due to the fact the engine is designed for use in a bike and on corners the bike leans forcing the oil to the bottom of the sump and due to the depth of the sump that can be fitted to a bike, the sump overcomes most of the issues under braking and accelerating as well. But when placed in a car, the engine does not lean and combined with extreme braking and acceleration, issues become apparent when logging the data. Due to the high quality of the bearings, this is not always immediately apparent in some applications as the bearings can cope with quite high abuse without failure. However over longer periods of time eventually the bearing will fail causing catastrophic engine failure.

We found during testing that oil pressure would still fluctuate dramatically, even when we had a perfect supply of oil. What we discovered was that the standard oil pressure relief valve is damped by the oil within the wet sump, which it is submerged in. However once converted to dry sump there is quite often no longer oil in the sump of the engine. This meant that the oil pressure relief valve could not work properly. So we re-positioned the standard oil relief valve in the sump itself, this gave us 2 advantages; it meant that we could feed the unwanted oil directly into the supply line from the oil tank, which reduced oil wastage and kept a high level of oil in the tank. It also meant that the relief valve was then damped by the oil in the supply line, creating a very smooth oil pressure trace.

### Standard Oil Cooler Delete

We have been asked by several customers as to why the standard oil cooler option has been removed from our dry sump system. The reason is that when we attempted to fit an oil cooler, we noticed that the oil pressure would drop quite considerably. Whatever we tried, there would always be a pressure drop and as many Hayabusa owners would know, oil pressure is quite high when the engine is cold and as the engine heats up and the crank cases would grow, oil pressure would drop huge amounts. We have even seen oil pressure of 2PSI at tickover, if you only fit the oil cooler to the scavenge side, the pressure part of the system does not have to work as hard and we have seen significantly more oil pressure under all temperatures.

### Internal Scavenge Channels

The sump was designed in 2 neat pieces; the main part of the sump has channels machined into it allowing the dry sump system to scavenge oil from both front and back of the sump pan, so there is no need for any external scavenge pipes. The pan is then closed with a thin top plate, which is bonded to the main part of the sump pan. The sump pan is 30mm deep. The billet is extremely rigid & will add strength to your engine.

### Mounting Lugs for semi-stressed installations

We have also added 4 x M8 fixing holes, this allows the user to bolt the sump to a chassis of a car, if required to further increase the strength of their installation.



## Scavenge pump removal in situ

The twin stage scavenge pump replaces the original water pump (you will need to use an electric pump), which mounts directly to our billet dry sump pan without the need for any hoses. The pump can be easily fitted & removed in minutes if required. You will only need to provide a supply from your dry sump tank & a return to the tank (via oil cooler if required). The oil pump has been designed so it can be removed and fitted whilst the sump is in place, this allows the user to inspect many components without having to remove the sump or disassemble the engine further.

## Baffle plates not required - faster oil evacuation

We are quite often asked why a baffle plate is not fitted, there are several reasons for this. The first reason is that a baffle plate is designed to retain oil below it, so if the engine was wet sump there would be oil in the sump itself and as the vehicle corners, the baffle is designed to slow the oil movement beneath the baffle to stop it escaping. When an engine is dry sump, in theory there is no oil in the sump itself and therefore the baffle becomes an unnecessary component as there is no oil to retain. The other problem with using a baffle is that any oil that is falling into the sump itself will be slowed by the baffle, but in effect this is the opposite to what you need and any oil that is making its way to the sump should be allowed to reach it as quickly as possible, because the moment it reaches the sump the scavenge pumps then extract the oil and return it to the tank as quickly as possible.

## Suzuki Hayabusa Oil Choice

We recommend you contact your engine builder for their oil recommendation.

***Free technical support is available on our website. If you require personalised technical support training, this is available at a chargeable rate.***

SBD Motorsport Ltd  
Unit 15, Red Lion Business Park, Red Lion Road, Surbiton, Surrey. KT6 7QD  
Tel: 020 8391 0121  
Website: [www.sbdmotorsport.co.uk](http://www.sbdmotorsport.co.uk)

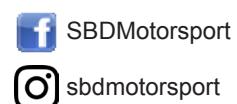

# SBD Hayabusa Dry Sump System Connections (OS-DSK-BUSA-01)

**Please note:**  
Two catch tanks are used due to different flow characteristics

