

December 2018

SBD FUEL INJECTION ASSEMBLY AND SET UP INSTRUCTIONS 2.0L VAUXHALL HIGH SPECIFICATION TAPER THROTTLE KIT

SBD would like to thank you for choosing the taper throttle injection kit.

The tapered throttle body system which Richard Jenvey and Steve Broughton of SBD Motorsport have developed back in 1995 for the 2.0L XE originally at that time for a touring car project which has been so successful, even spawning many copies.

We decided that the fact that the 2.0L XE was still very popular, that is was time to look at the design again which everything that we had learnt in developing the Hayabusa and Duratec high specification throttle bodies. We contacted Jenvey Dynamics again, who have helped us to develop all our own special throttle body projects over the years and started designing a new intake system to suit the 2.0L XE as well as it's larger capacity versions, 2.2L, 2.3L, 2.4L & 2.5L which are now being built.

The tapered throttle body has a 54mm entry tapering down to 52mm butterfly. The taper then continues on through the throttle body then into the manifold and down to the cylinder head. The port shape we have developed to match up with our high specification CNC ported cylinder head, this means the inlet manifold should not require any porting when mated to one of these cylinder heads. The injectors are now mounted underneath the throttle body pointing at an upwards direction at the correct angle so that upon butterfly opening high gas speed is achieved allowing very fast throttle response. Because the injector is mounted much higher up the inlet track, this allows improved air/fuel mix, which we have found in many tests to give identical improvements to that seen with an 8-injector set up but also allows for reduced complexity. Great care has also been taken to ensure that the package is very neat and compact as possible, which means we can use a flat air filter back plate without the need for any complex stepped back plates.

The system comes with a build in single cable throttle linkage mounting assembly, but we have designed options that will allow the use of the more traditional single or twin cable Jenvey throttle linkage kit.

The overall length of the system including airhorns is identical to the length of our earlier system TP2K. This means that any customers using the original system with 90mm air horns can easily upgrade to the latest system.

The wiring looms have been specially designed to be as neat as possible and to cover as many applications as possible. These wiring looms are kept on the shelf and are available in both front & rear wheel drive applications.

When ordering your kit most of the components should be in stock, which means that we can usually despatch your kit immediately.

On our display engine at Autosport International Show.



IMPORTANT INFORMATION YOU WILL NEED TO KNOW

There are many references to cylinder numbers in this document. The position of No. 1 cylinder is the cylinder nearest to the camshaft belt end of the engine and therefore No. 4 position is situated at the flywheel end of the engine.

Taper throttle inlet manifold



Taper throttle bodies



The air temperature sensor should be mounted so it will measure ambient air temperature & not engine bay temperature. If in a kit car then somewhere low in the engine bay. If in an Escort or Manta type car, then through the inner wing or in behind bulkhead.

KIT COMPONENTS

Each kit is designed specifically for your requirements, therefore it is not possible to show all the components in your kit (please refer to your invoice for the parts that are included in your kit, however shown below is the minimum parts required to install this kit.



OTHER PARTS YOU WILL NEED TO ASSEMBLE YOUR KIT

1. Air box / filter and backing plate (recommended).
2. JIC (-6) fuel couplings and braided high-pressure fuel hose.
3. Thread locking compound (Loctite 243, 542 & 222 recommended).



SPECIAL TOOLS YOU WILL NEED TO ASSEMBLE YOUR KIT

- Laptop (recommended)
- Easimap 6 software, downloaded free from our website (recommended)
- SBD Basic CAN mapping kit & adapter (recommended)
- If not using any of the above, you will require: Digital voltmeter
- Fuel pressure test gauge (recommended so you can confirm your fuel system is working correctly)
- Synchrometer (Vacuum gauge), see above right

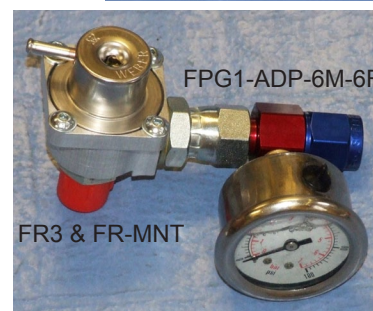

Important note for TP-VX-2.0-K3

This throttle body kit has been designed with the optimal port shape and position to suit a high specification cylinder head using our latest 2013 port design, by designing the manifold to be a direct fit it has allowed us to produce a manifold with the minimum weight, yet sufficient strength to survive in harsh competition environments, this also removes the need for the customer to port the manifold themselves and risk ending up with too thin a wall thickness.

For customers using this kit on pre-2013 SBD CNC heads, hand ported or standard cylinder heads it is advised that the port entry on the head is enlarged to match our manifold size and shape.

Care must be taken not to port the head too far, we advise blending only an initial 10-15mm in depth into the port, if you wish to have the head CNC machined at a later date to our spec, ensure only the minimum material is removed, otherwise you may have compromised the port shape by removing too much material which cannot be resolved when machined.

Due to the accuracy achieved in our CNC machining operation we can blend the inlet of the port throat further, however we suggest you do not attempt this by hand as wall thickness to the water jacket can be an issue.

COIL CONNECTOR PIN OUTS

WHITE/BLACK - IGN/DRIVE 1
WHITE - +12V
WHITE/GREEN - IGN/DRIVE 2

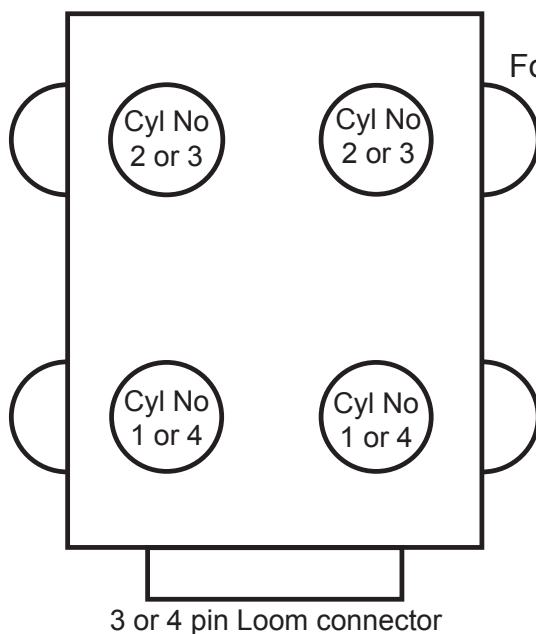
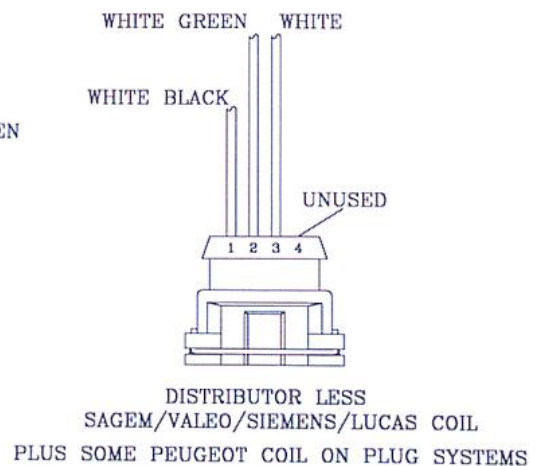
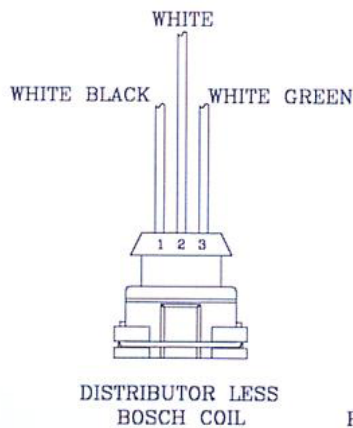
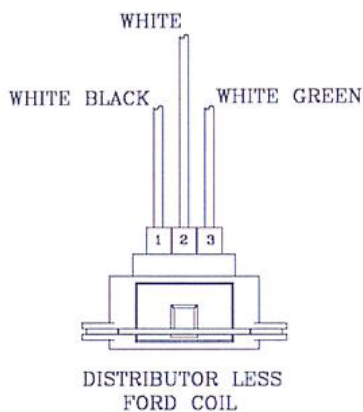

COIL CONNECTION FOR HT LEADS

For use with: -Sagem/Valeo/Bosch/Siemans/Lucas coils

These coil packs, when used with the MBE ECU, use a wasted spark system. Both cylinders spark at the same time. That is why you can install 1 & 4 on either post & the same for 2 & 3.

SBD FUEL SYSTEM PLUMBING WITH FUEL SWIRL POT (RECOMMENDED)

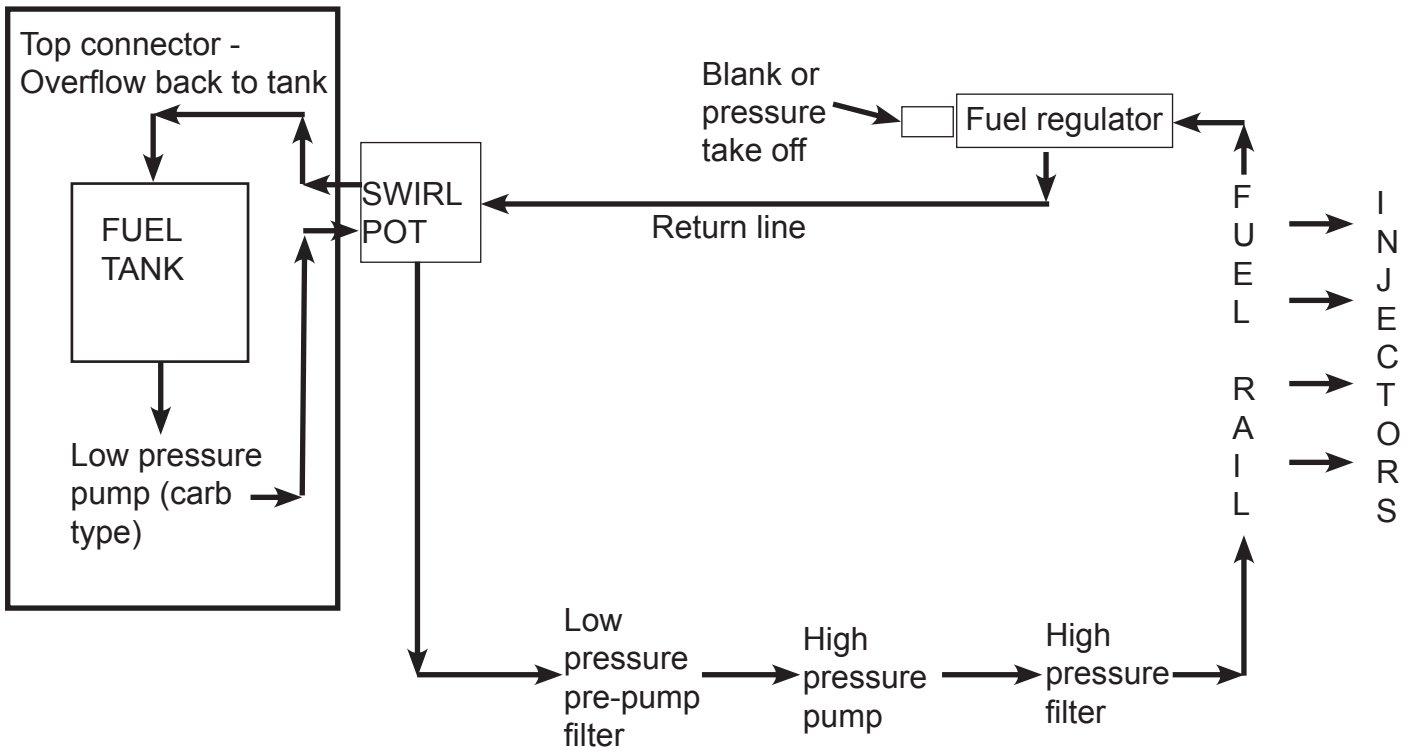

High pressure pump must be mounted below the level of swirl pot to allow for gravity feed

Notes

1. Use straight connectors where possible as they are approx. 1/3 of the price of angled ones.
2. High-pressure & Return to swirl pot use JIC -6 couplings.

SBD FUEL SYSTEM PLUMBING WITHOUT FUEL SWIRL POT

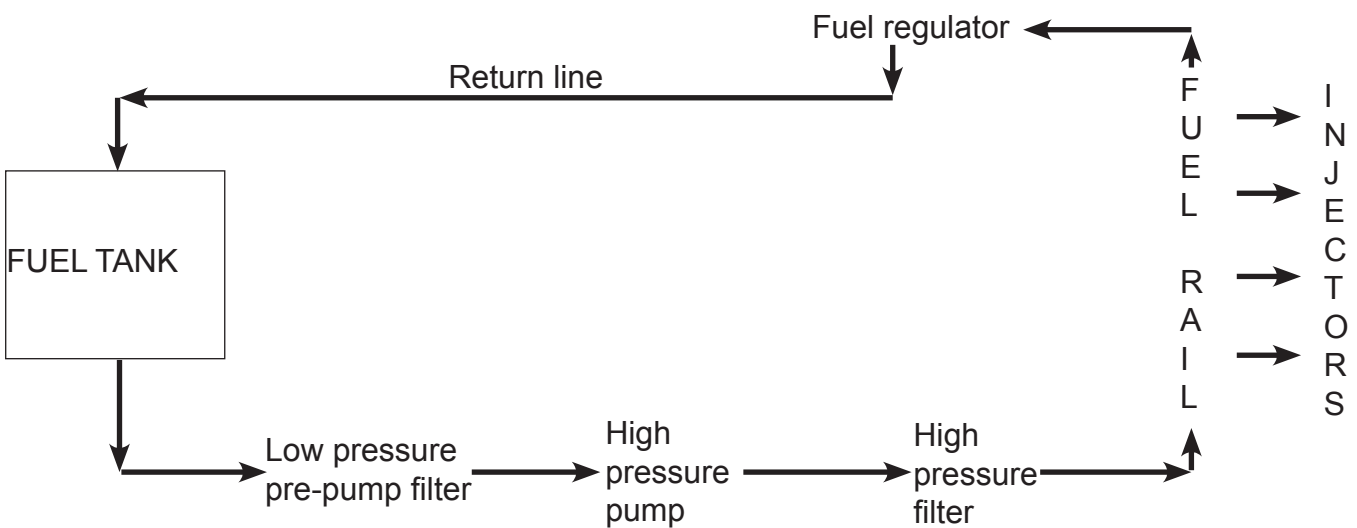

High pressure pump must be mounted below the level of fuel tank

FITTING THE WATER TUBE

STEP 1

For all engines using a traditional mechanical water pump, we strongly advise a thermostat is used, which then requires the water elbow to be fitted. This is crucial as it provides the correct water bypass route when the thermostat is closed.



If you are using a variable speed water pump, then the thermostat can be removed and the manifold blanked off.

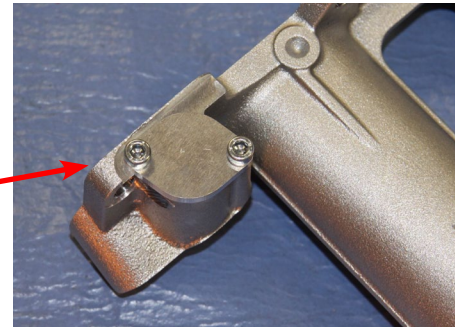

STEP 2

On all installations, apply thread sealant (recommended Loctite 542) and fit bleed fitting.

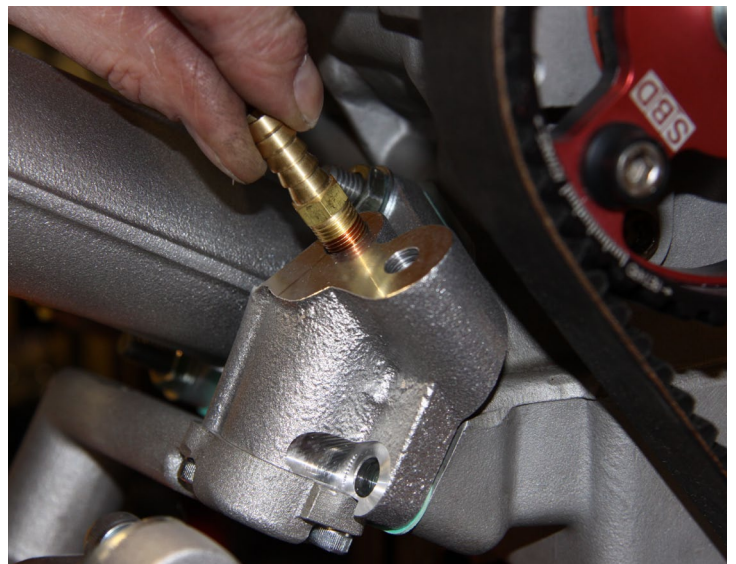
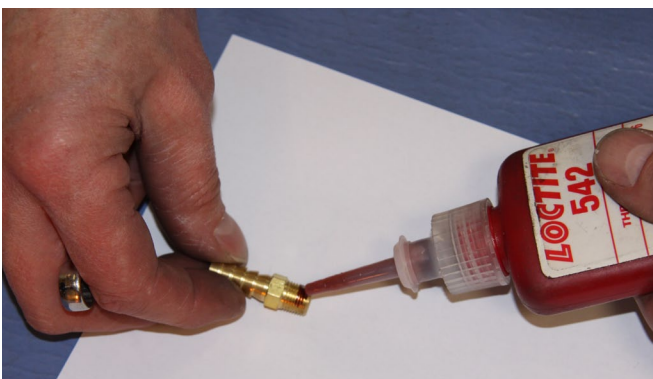

STEP 3

If SBD supply the injectors, they will come in a matched set of 4 and will include a sachet of silicone lubricant to aid assembly.



INJ-690P
High flow injector, blue
690cc, 12.5 Ohms

STEP 4

Fit the injectors to the fuel rail by applying a small amount of lubrication to the plastic o-ring spacers, ensuring that the spacer fits squarely into the cup. The spacers are not necessarily on all injector types, please do a trial fit by moving the injector up and down to ensure the o-rings of the injectors remain in full contact with the throttle body bore and fuel rail bore.

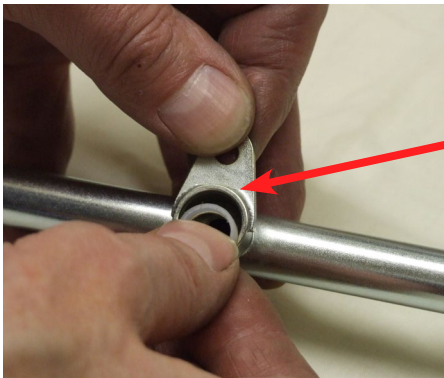

Insert the injectors spacers
into the fuel rail

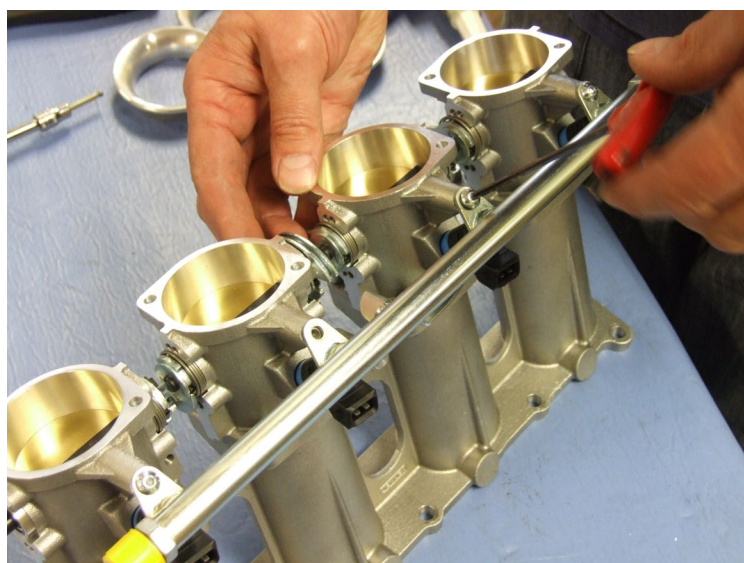
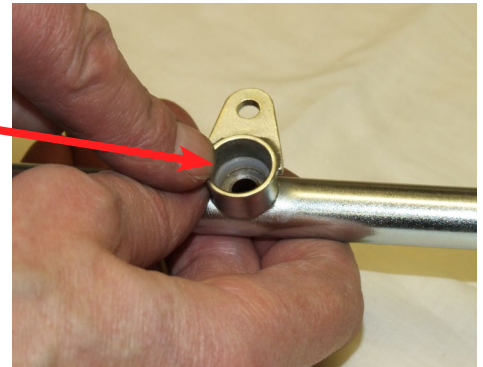

STEP 5

Insert the injectors into the fuel rail using a small amount of lubricant (silicone lubricant works well). The fuel rail with injectors can now be fitted into position (again lubricate the injectors) by locating the bottom of the injectors into the pockets in the inlet manifold and gently pushing on the fuel rail at both ends. The injectors will only press in so far until the mounting arms on the fuel rail rest against the throttle bodies. Tighten the bolts to hold in position.

The fuel rail that is fitted to this kit uses a high pressure coupling system called JIC-6 for use with a braided reinforced hose. This type of coupling and hose design are much safer to use in motorsport than ordinary push on hose, which are regularly seen on road cars.

STEPS 6-7

You will need the throttle potentiometer (including brackets & bolts).

Depending on the type of vehicle this system is being fitted to, the throttle potentiometer can be fitted to either No. 1 or No. 4 throttle body. For most kit car and front wheel drive applications the throttle potentiometer will be fitted onto throttle No. 4. This position will be determined by where the connecting socket is fitted on the wiring loom. Refer to your wiring loom drawing for confirmation.

You have two throttle potentiometer options PT1-SS or PT11-SS.

IMPORTANT NOTE

In most Cases the voltage for the throttle pot when the engine is at idle is 0.35 - 0.36 Volts, however this is only for engines that have been programmed by SBD. You will also need to know the units of air when the engine is at idle (this will be in KGs per hour) & the fuel pressure your engine was mapped.

Follow either Step 6 or 7 depending on where the throttle potentiometer is be fitted to.

STEP 6

NOTE

If the throttle potentiometer is being fitted to No. 4 throttle body follow the instructions in this Step.

The throttle potentiometer will only operate correctly if fitted the correct way around. For fitting to No.4 throttle body the throttle potentiometer must be mounted with the lip on the side, facing outwards, and the clamping plate will then fit on over the lip.

Note – Do not fit clamping plates, bolts & washers yet.

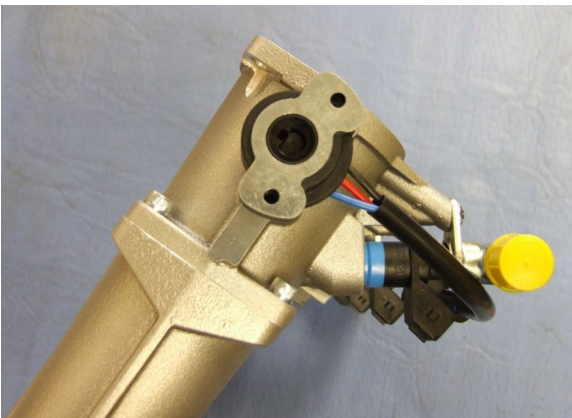

STEP 7

NOTE

Follow the instructions in this step only if your throttle potentiometer is being fitted to No. 1 throttle body.

The throttle potentiometer will only operate correctly if fitted the correct way around. For fitting to No.1 throttle body the throttle potentiometer must be mounted with the lip on the side facing inwards (as shown in Fig 24), and the clamping plate will then fit against the outside of the potentiometer.

Note – Do not fit clamping plates, bolts & washers yet.

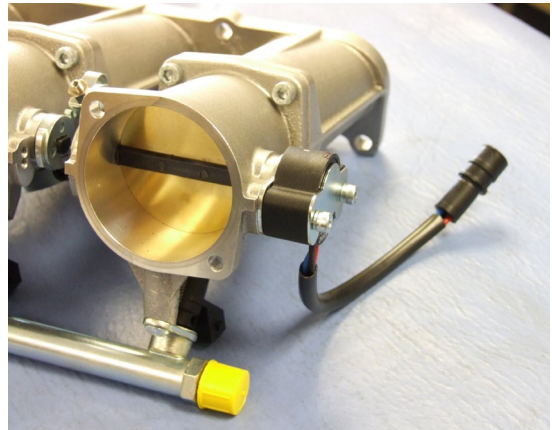

IMPORTANT

Please read the following carefully, as failure to do so may result in damage to your system.

To confirm that the throttle potentiometer is fitted correctly, you will need to gently hold the throttle potentiometer with your hand, and then slowly open the butterflies using the primary operating lever. If the throttle potentiometer is fitted correctly you should be able to achieve full throttle without the throttle potentiometer body moving. If the body does move then fit the throttle potentiometer on the other way around and repeat this step. Fit the clamping plate and then screw bolts & spring washer onto the throttle body until they just begin to tighten.

Do not tighten the bolts & spring washers yet, as the throttle potentiometer will need adjusting later on.

STEP 8

We have had cometic a special inlet manifold gasket to suit our new port shape and position - **GSK-VX2-01**.



Alternatively a standard gasket will need to be modified.

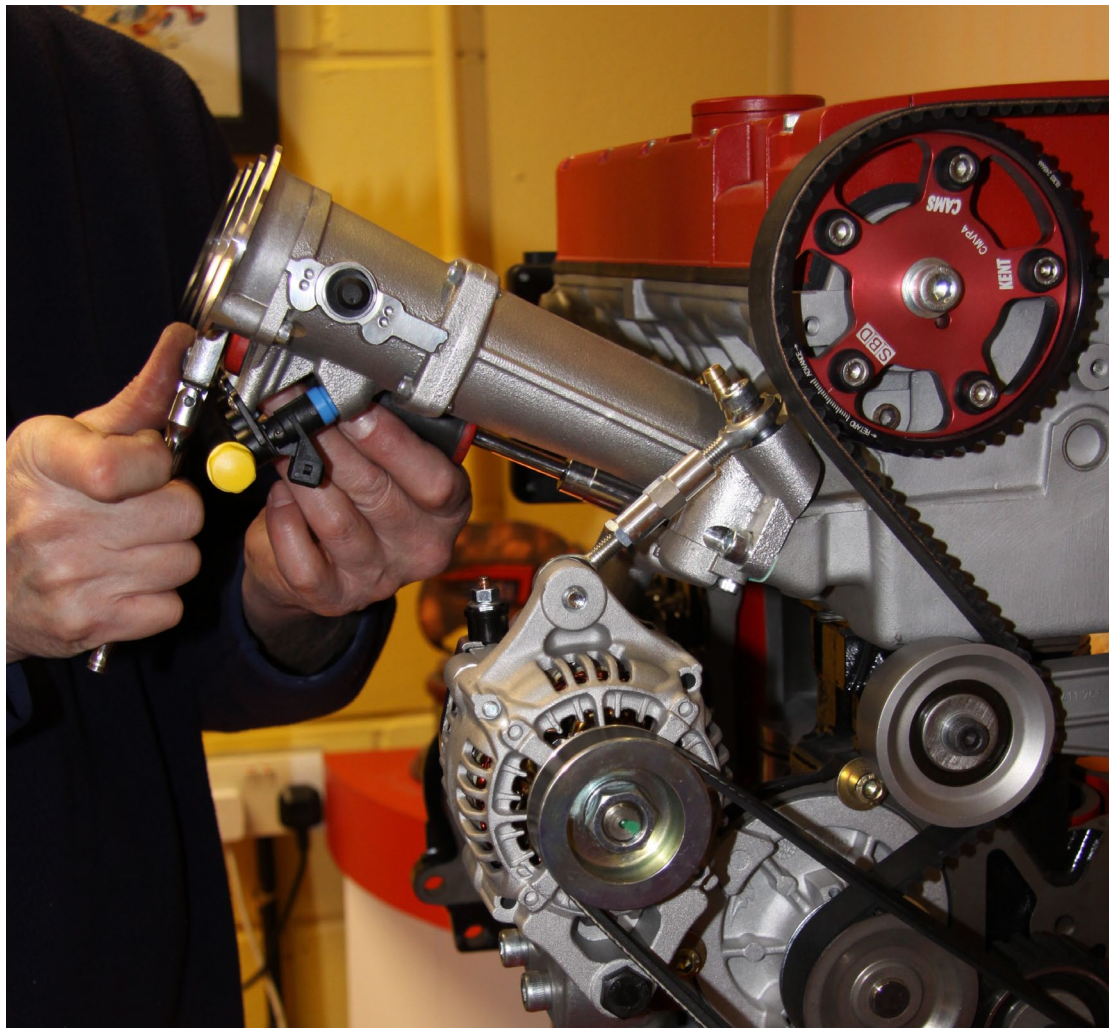

STEP 9

Do not fit the fuel regulator directly on to the fuel rail, because certain engines can produce a resonant frequency, which can make the regulator vibrate & break the fuel rail. Ensure fuel lines fitted to it are not straining.

Unscrew the 4 screws on the regulator mount, lubricate the 2 seals on the regulator (we recommend a silicone grease), then carefully push the regulator into the mount ensuring the seals are damaged. Refit the 4 screws to retain the regulator.

Tighten the inlet & outlet fittings on the regulator mount.

The inlet to the fuel regulator is a female -6 & the outlet is a male -6.

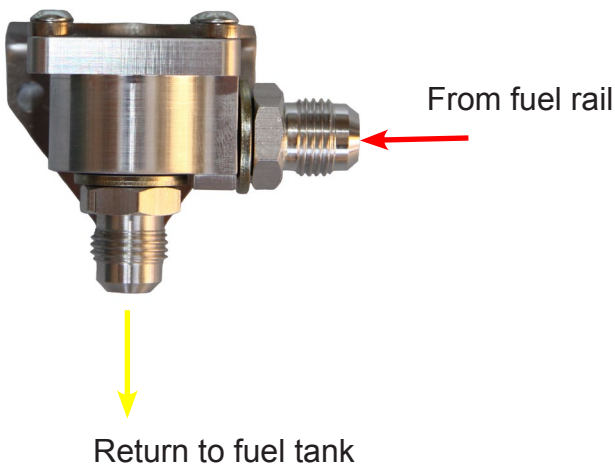

NOTE

The vacuum pipe fitted to the top of the fuel regulator is not used with this kit and can be left vented to atmosphere.

STEP 10

When fitting your throttle cable, you will need to ensure that your cable clamp (or fixed end eye) does not protrude beyond the end of the cam as shown in the picture on the right, otherwise it will jam the throttle system when opening.



If you are using our own throttle cable kit, this comes with a shortened cable clamp as shown in the photo left. Our throttle cable kit, part number TC-K3 also includes an inline adjuster, which you can position anywhere in the throttle cable to make adjustment of the throttle cable. See more information on our website under that part number.



STEP 11

Connect loom to various components as labelled.

MBE9A4 - The injector plugs labelled with cylinder numbers.

The air temp sensor should measure ambient air temperature so should be mounted away from engine heat.

Connection of interface wires: -

Pin 1 Purple or Red Switched +12v (Ignition)

Pin 2 Orange +12v out to fuel pump

Pin 3 Green Taco signal

Pin 4 Blue/White or White Gear change light

Connect either way as described in step – 20.

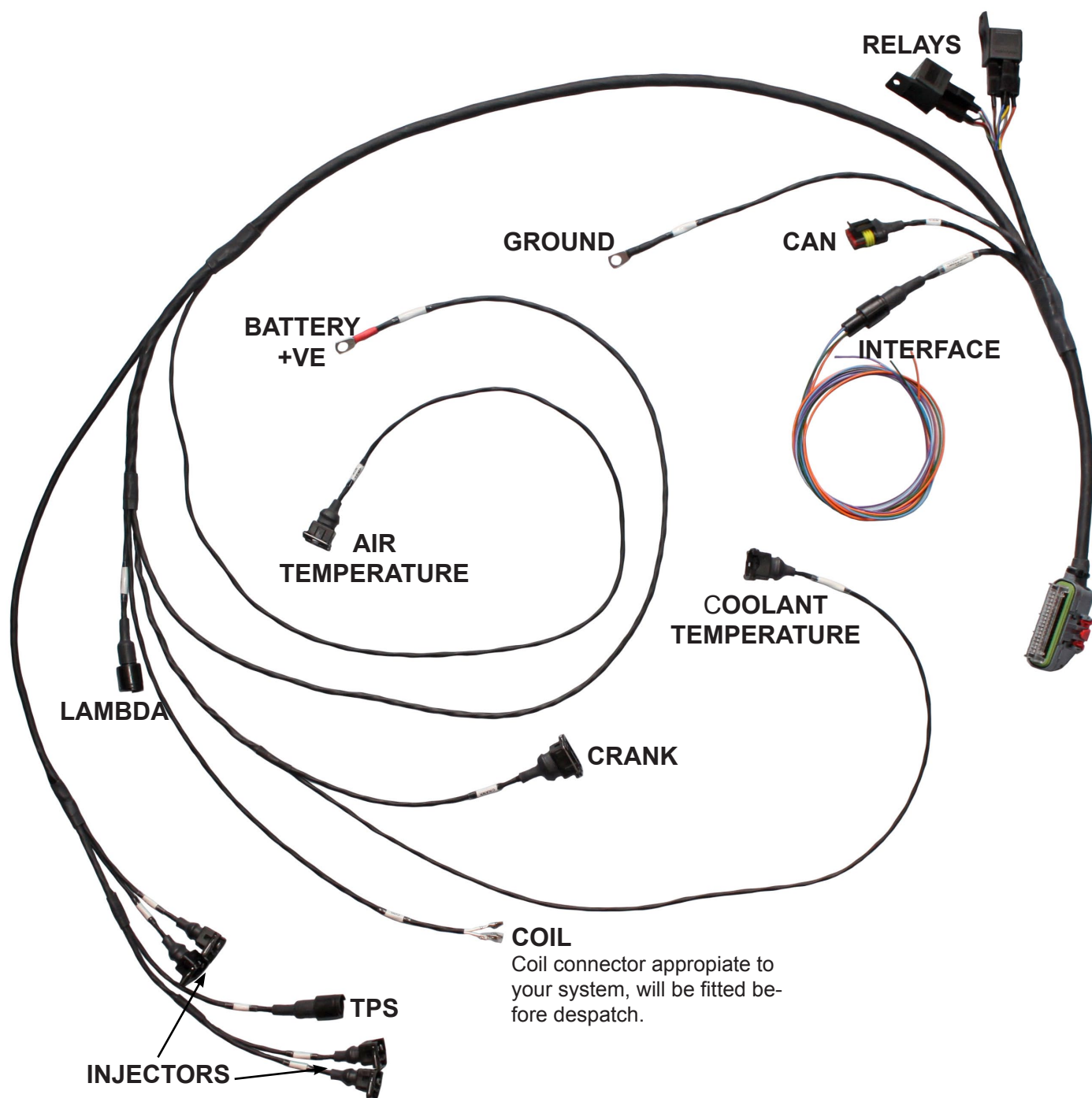

STEP 12

Installation of a gear change lamp

There are a large range of lights & LEDs available on the market, we suggest you use RS Components or a similar supplier. There is a choice of 2 designs for wiring in a shift light, those with a current draw of over 1amp and those which draw less than 1amp. You could also use a bleeper system, which can be fitted into the driver's crash helmet, please check our website for more information

Installation of a large gear change lamp over 1 amp

Relay connections

- Pin no. 85 - Connect to interface sure seal pin no. 4
- Pin no. 86 - Connect to ignition switched +12V
- Pin no. 87 - Connect to gear change lamp
- Pin no. 30 - Connect to ignition switched +12V

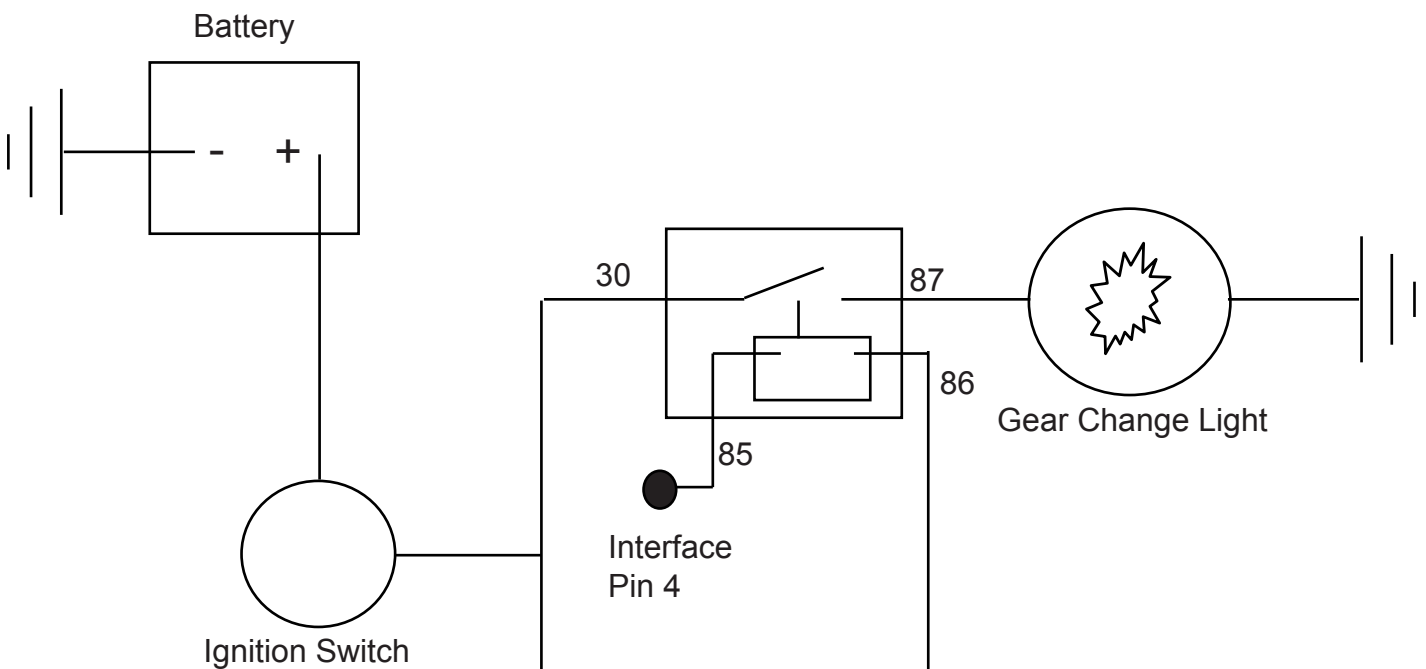

Installation of a small gear change lamp less than 1 amp

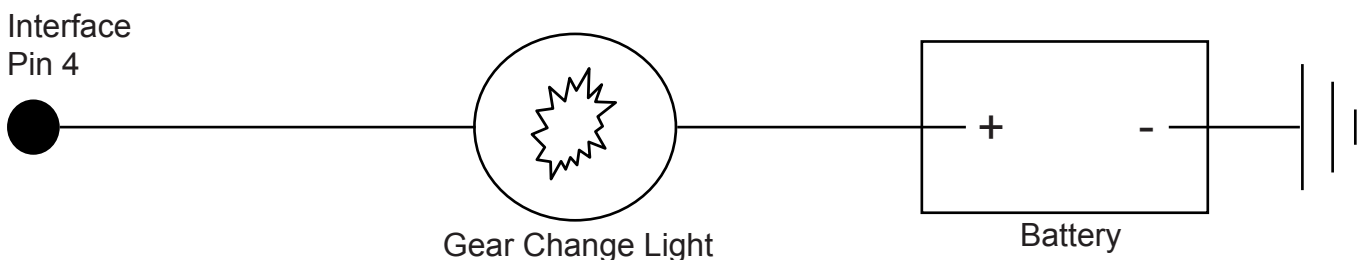

SETTING UP PROCEDURE

It is very important to read first and understand the complete set up procedure in order to enable you to set up your throttle system accurately. You should have some assistance for the setting up. All of the steps in the setting up procedure are very critical to ensure correct and efficient running of your kit. Failure to accurately follow any part of these instructions will result in your kit not performing to its optimum.

Throttle Stop Screw

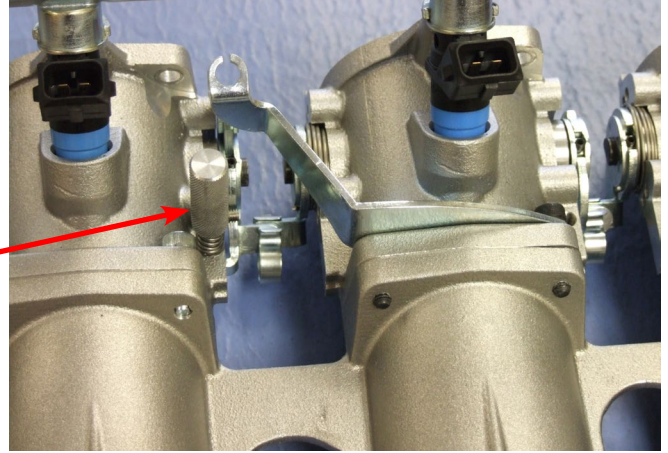

STEP 1

All our throttle bodies are now pre-assembled and set up in the factory before despatch, therefore you should only be required to set the amount of air being drawn through the throttle bodies (Kg/Ph) and the voltage at tickover. The amount of air at idle (kg/ph) varies depending on the kit, this information can be obtained from within the ECU's device info, it would have also been printed out when your ECU was programmed. There is also information within this instruction sheet, but please note that this information does vary so it is always best to look at the information within your ECU.

IF YOUR THROTTLE BODIES HAVE BEEN DISASSEMBLED PLEASE SEE A DIFFERENT INTRUCTION SHEET.

Unscrew throttle stop screw on no. 3 so that it is off of the operating arm and the butterfly is fully closed.

STEP 2

Initial setting for throttle potentiometer

Switch on your ignition only.

Do not attempt to start your engine yet!

Tighten throttle potentiometer clamping screws sufficiently so you are still just about able to move the potentiometer with your fingers. Using either Easimap 6 where the throttle position's voltage is easily displayed on the basic page or a voltmeter (if using a voltmeter, it is suggested to use 2 small bits of wire (straighten out a paperclip), slide the pieces of wire down the side of the sureseal connector on the throttle pot into Pin 3, which will give you the throttle signal and the 0v into Pin 2.

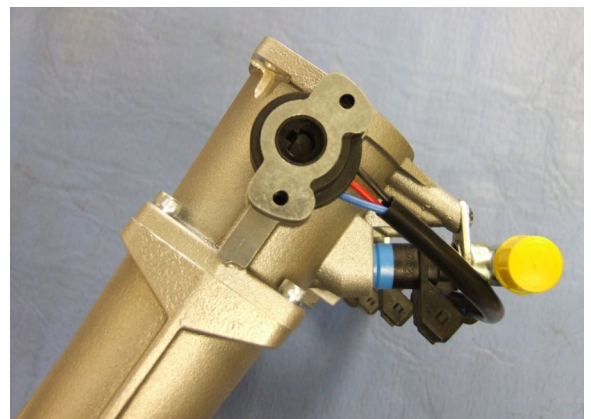

Set voltage to 0.25v, by twisting potentiometer (*****This is an initial setting & you must not go back to this reading again.*****).

Leave the voltmeter connected, as you will need this later.

Screw the throttle stop screw clockwise on throttle No.3 until you reach 0.30v on your voltmeter or showing on Easimap 6.

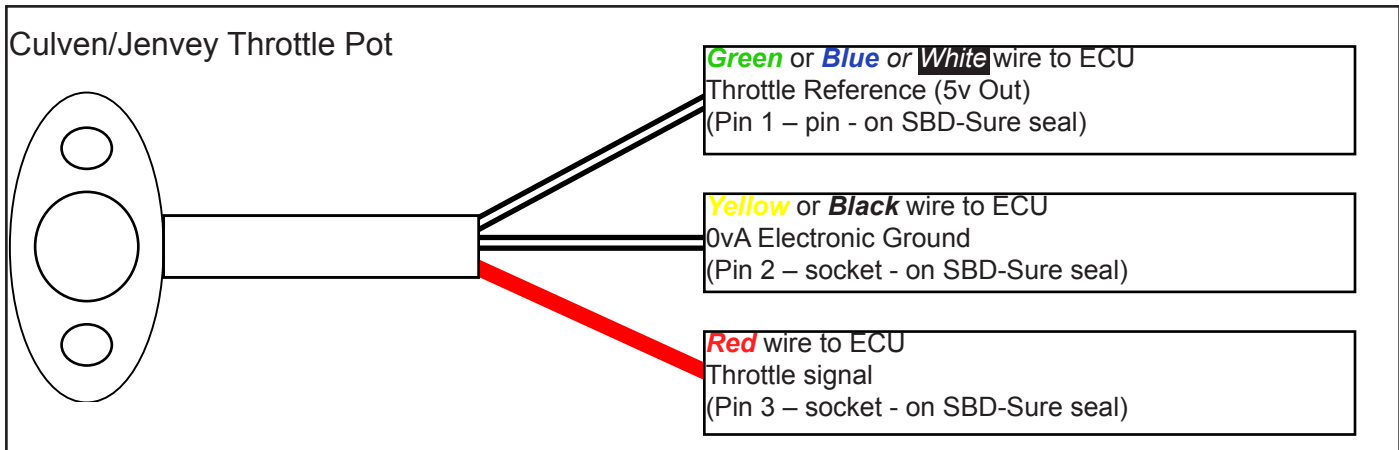

MBE9A4/9A8 ECU Pin out for Throttle sensor

5v Reference = Pin 22 of ECU
 0vA Electronic Ground = Pin 23 of ECU
 Throttle Signal = Pin 20 of ECU

Do not start your engine yet!

You will first need to set the fuel pressure. Turn ignition on & off to build up pressure as ECU cuts fuel pump when engine is not turning.

TP Kit	Fuel Pressure	Injector Type	ECU Type	Idle RPM/kg/Ph	Cam Profile
TP208 2.0L 16v XE	3 Bar (44psi)	INJ-690P	MBE9A4	980 / 5.5	Standard
TP225H 2.0L 16v XE	3 Bar (44psi)	INJ-690P	MBE9A4	1025 / 6.0	SBD284IN @ 2.77mm SBD278EX @ 2.57mm
TP230M 2.0L 16v XE	3 Bar (44 psi)	INJ-690P	MBE9A4	1100 / 6.0	SBDM278-11.78IN @ 3.46mm SBDM269-11.42EX @ 2.59mm
TP245M 2.0L 16v XE	3 Bar (44psi)	INJ-690P	MBE9A4	1100 / 6.0	SBDM278-11.78IN @ 3.46mm SBDM269-11.42EX @ 2.59mm
TP250M 2.0L 16v XE	3 Bar (44psi)	INJ-690P	MBE9A4	1250 / 8.0	SBD304IN @ 4.40mm SBDM295-11.6EX @ 3.95mm
TP270M 2.0L 16v XE	3 Bar (44 psi)	INJ-690P	MBE9A4	1200 / 8.0	SBD300IN @ 4.30mm SBD290EX @ 3.60mm
TP300M 2.0L 16v XE	3 Bar (44 psi)	INJ-690P	MBE9A4	1600 / 10.0	SBD300IN @ 4.30mm SBD290EX @ 3.60mm

Note – When you have completed your fuel system, it is always worth checking with an in-line fuel gauge as shown earlier in the instruction sheet. It is suggested that the pressure is checked not only at idle but also when the engine is revved, this is to ensure that not only do you have the correct pressure, but you also have sufficient fuel flow. If the pressure drops when the engine is revved, we then suggest you check your fuel hoses, fuel filters and fuel pumps to ensure they are all functioning correctly as this could damage your engine when put under load.

Injector Type

INJ-690P
 High flow injector, blue
 690cc, 12.5 Ohms



STEP 3

Starting engine for the first time

When idle voltage & fuel pressure have been set, you can attempt to start the engine. You may have to hold the throttle to keep engine running.

To get the engine to run on its own you can screw the throttle stop clockwise slightly (Ensuring you do not go above the 0.36v & don't go more than approx 2 units higher or 1 unit lower than the idle Kg/Ph setting for your kit) until engine runs on its own, even if it's not smoothly.

STEP 4

Balancing the throttle bodies to read the same

Engine revs may increase during this stage, unscrew the throttle stop to decrease revs (you can re set pot voltage in next step) to keep it within 2 units above required Kg/Ph setting for your kit.



You now need to balance the butterflies using the synchronometer.

Start by reading airflow through No3 body, then No4 body, use adjuster screw A to adjust the airflow into cylinder No4, once the pair are matched, lock the locknut.

Then measure the airflow through No2 and use adjuster screw B to adjust the airflow into cylinder No2 until it matches cylinder No3 then lock the locknut.

Then measure the airflow through No1 and use adjuster screw C until it matches cylinder No2, then lock the locknut.

When all 4 throttles read the same amount of airflow they are balanced.

Give them a final check to ensure the airflow is the same across all four cylinders.

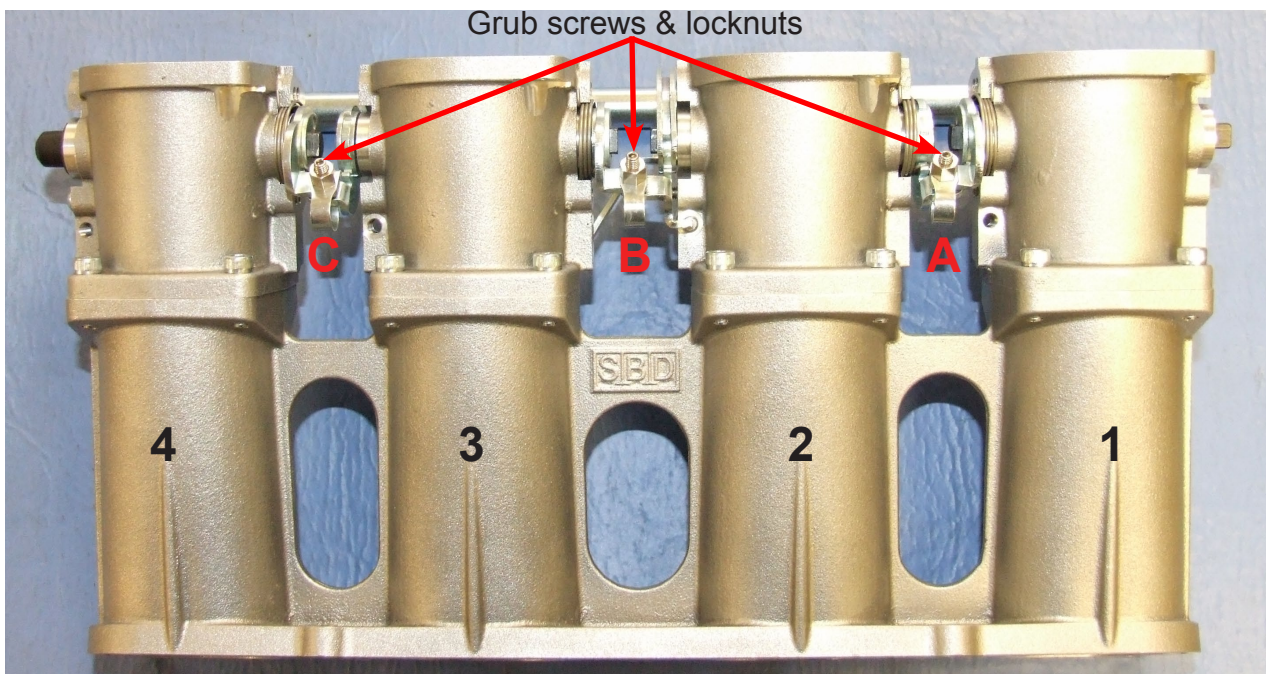

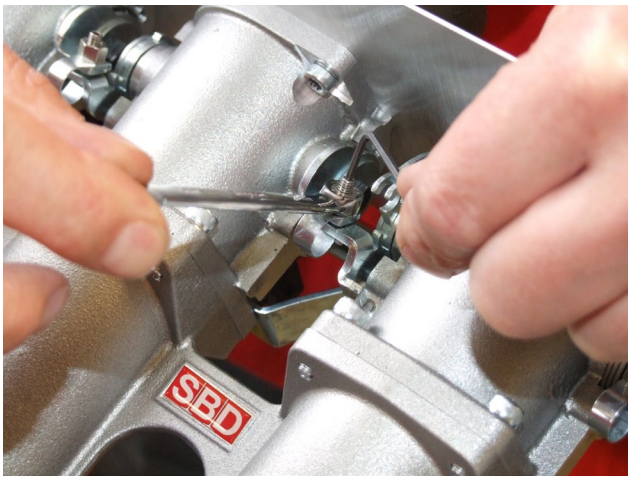

Adjusting the grub screws & locknuts

Adjusting the throttle stop screw

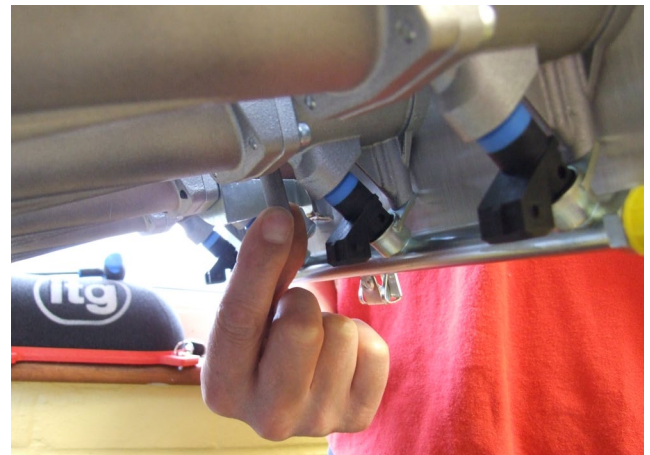

Using a synchronometer.



STEP 5

Fine tuning airflow & throttle potentiometer

You will have to do this step a few times to get everything right. – It's worthwhile spending extra time & taking care on this stage because if everything is not correct then engine will not idle properly.

With the engine still running, butterflies balanced insert the synchronometer on No.3 body & set the correct amount of Kg/Ph airflow for your kit (by adjusting throttle stop screw). Once you have the correct amount of Kg/Ph, re set the throttle potentiometer to read 0.35/0.36v.

Keep checking & adjusting until Kg/Ph airflow & throttle potentiometer are correct for your kit. (RPM will be correct when Kg/Ph is set)

Tighten the throttle potentiometer clamp so that it can't move. – DO NOT OVERTIGHTEN AS THIS WILL CAUSE THE POTENTIOMETER TO JAM UP AND STICK AND COULD ALSO DAMAGE THE POTENTIOMETER

Re check all readings again & re adjust as necessary.

Once you are finally happy with everything, it is suggested that you use a thread locking agent on the throttle stop screw, we normally use a small amount of Loctite 222. It is not a too stronger Loctite and still allows adjustment but helps to prevent movement of the throttle stop screw from vibration.

Please be aware that Technical Support involving our Technicians is chargeable

SBD Motorsport Ltd
Unit 15, Red Lion Business Park, Red Lion Road, Surbiton, Surrey. KT6 7QD
Tel: 020 8391 0121
Website: www.sbdmotorsport.co.uk

 SBDMotorsport

 sbdevelopments